

# IFRF MEMBERS CONFERENCE

June 8-10, 2009 Boston, MA



**Presented by**  
**Great Southern Flameless, LLC**  
**“GSF”**

One of the  
**Great Southern Group of Companies**

---

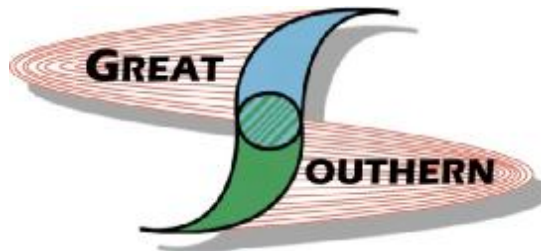

Great Southern  
Technologies, LLC

Great Southern  
Flameless, LLC

Great Southern  
Independent, LLC

# William Gibson, President

## Combustion Patents

Co-inventor and assignor of record

### Nitrogen Oxide Control Using Internally Recirculated Flue Gas

U.S. Patent: 5,135,387  
Original Filing: October, 1989

### Multiple Purpose Burner Process and Apparatus

U.S. Patent: 5,284,438  
Original Filing: January, 1992

### Method to Facilitate Flameless Combustion Absent Catalyst or High Temperature Oxidant

U.S. Patent: 6,796,789  
Original Filing: January, 2003

# Upcoming Air Quality Regulations for CO<sub>2</sub> Greenhouse Gas

- 🔥 16% Reduction in CO<sub>2</sub> Emissions by 2020
- 🔥 80% Reduction by 2050



- 🔥 Cap-and-Trade Type Regulation (\$\$\$)
- 🔥 YES - We Still Must Meet Consent Decree Compliance for NO<sub>x</sub>

# Multiple Technologies for CO<sub>2</sub> Reduction

- 🔥 Pre-Combustion Fuel Conditioning
- 🔥 High Efficiency Combustion Technologies
  - ü Oxy-Fuel Systems
  - ü High Temperature Air Combustion (HTAC)
  - ü Flameless Combustion
- 🔥 Post-Combustion CO<sub>2</sub> Capture and Storage

BACT???

# Cap and Trade

- 🔥 Will Cost You Dearly
- 🔥 Will Be Set Just Below the Costs For Pre and Post Combustion Systems
- 🔥 You Lose Control
- 🔥 Zero Return on Investment

# Pre and Post Combustion Systems

🔥 Will Cost You Dearly

🔥 Increased Operating and Maintenance Costs

🔥 You Keep Control

🔥 Zero Return on Investment

# INTRODUCING



Conventional Heaters with  
Flameless Combustion

Capability  
(patents pending)

the next generation of direct  
fired heaters



# GSF Flameless Combustion

- 🔥 Same Installed Cost For Retrofit or New Double Fired Heater with Balanced Draft Air Preheat System
- 🔥 You Keep Control
- 🔥 Significant Return on Investment with Energy Savings and Increased Run Lengths

# Evolutionary Impacts





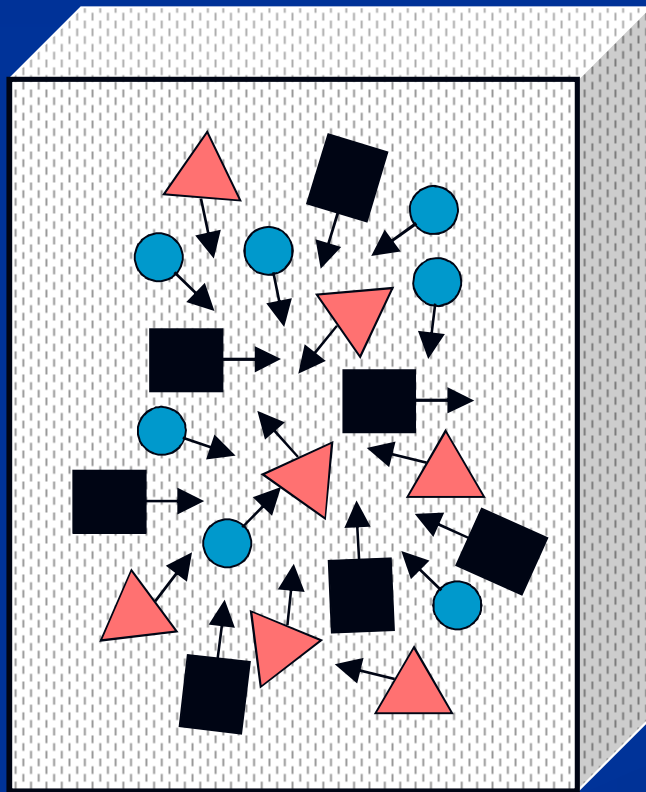

	1950's	1980's	Flameless Combustion
Radiation	Uneven	Uneven	EVEN
Fuel efficiency with low NOx	Low	Low	HIGH
Fuel filters	No	Yes	NO
Long run lengths	No	No	YES
Low fouling rates	No	No	YES
Flame/hot gas impingement	Yes	Yes	NO
Safe operation	Good	Good	EXCELLENT
Repeatability of performance	Marginal	Good	EXCELLENT

# Conventional vs. Flameless Combustion

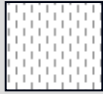
## Conventional Combustion

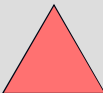





	Inert
	O <sub>2</sub>
	H <sub>2</sub>
	C

- Close Spacing
- Low Velocity
- Low Inert Level
- (3) T's of Combustion:
  - Time
  - Temperature
  - Turbulence

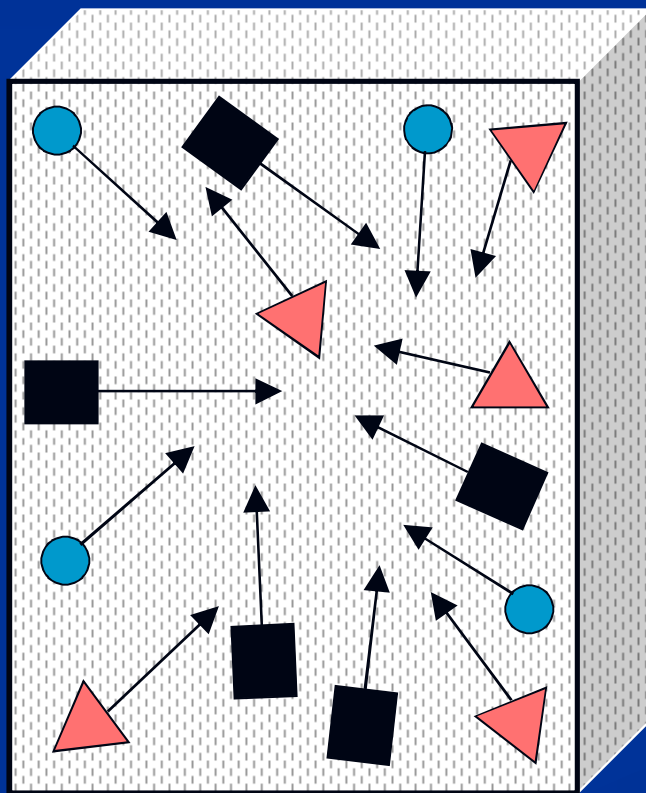
# Conventional vs. Flameless Combustion

## Flameless Combustion

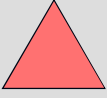

	Inert
	O <sub>2</sub>
	H <sub>2</sub>
	C

- Open Spacing
- High Velocity
- High Inert Level
- (2) T's and (1) D
  - Time
  - Temperature
  - Diffusion

# Conventional vs. Flameless Combustion

## Results

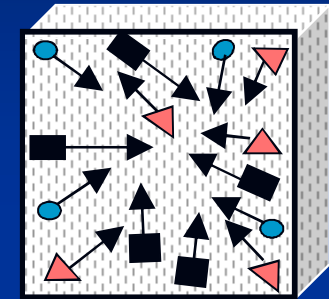
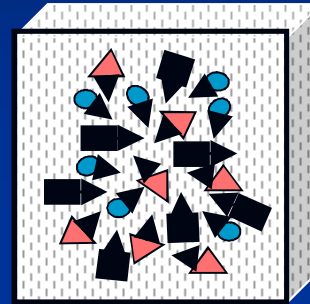

	Conventional	Flameless
Energy release/unit volume	High	Low
Localized temperature	High	Low
NOx	High	Low
Combustion	Complete	Complete

# The Combustion Zone

## Flame Speed vs. Stability

Flue Gas Temperature

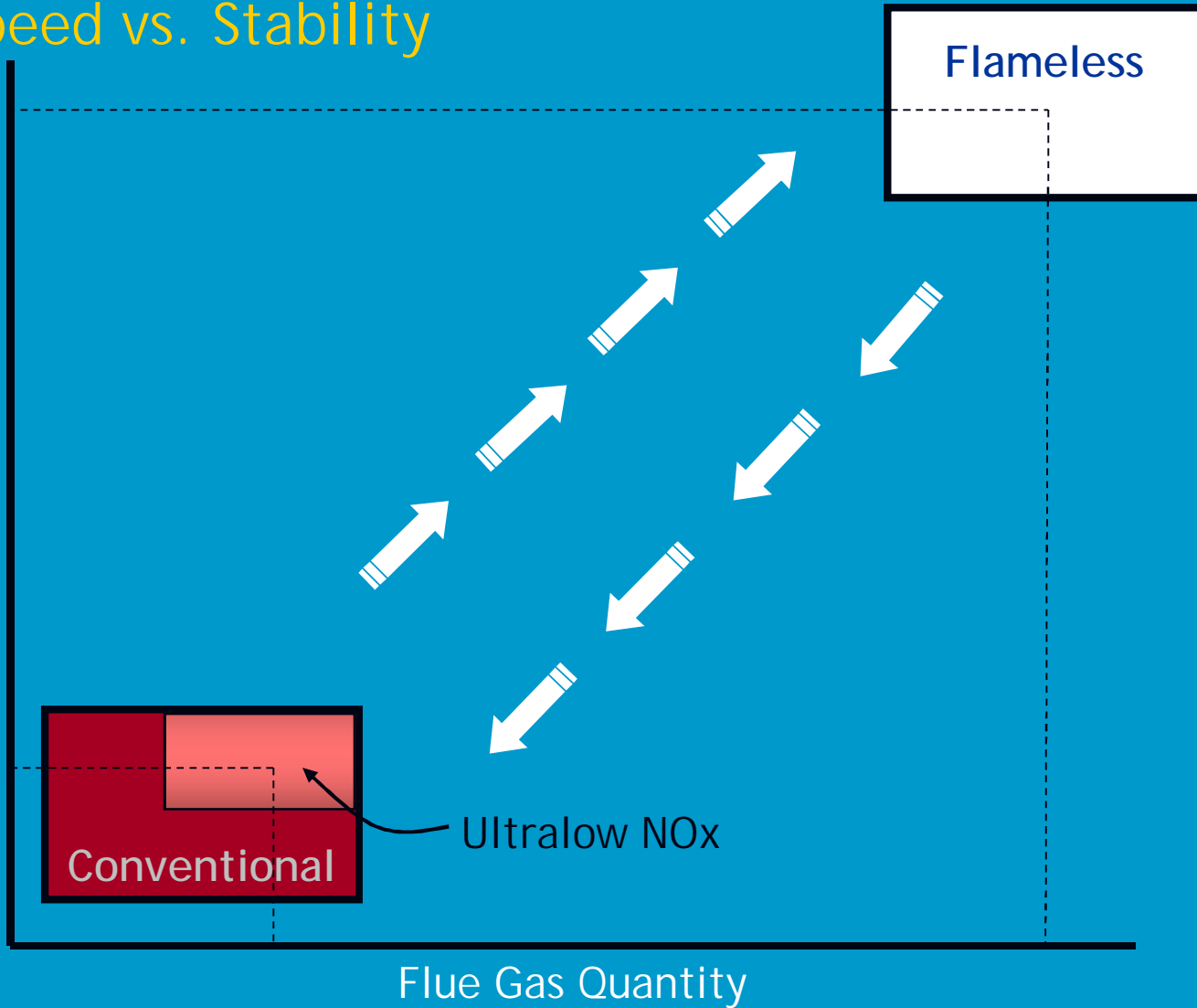

Great Southern Flameless, LLC

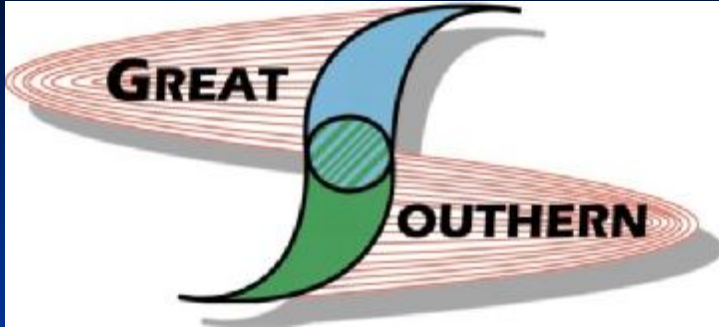

# Typical GSF Cabin Heater with Air Pre-heat System

General Arrangement

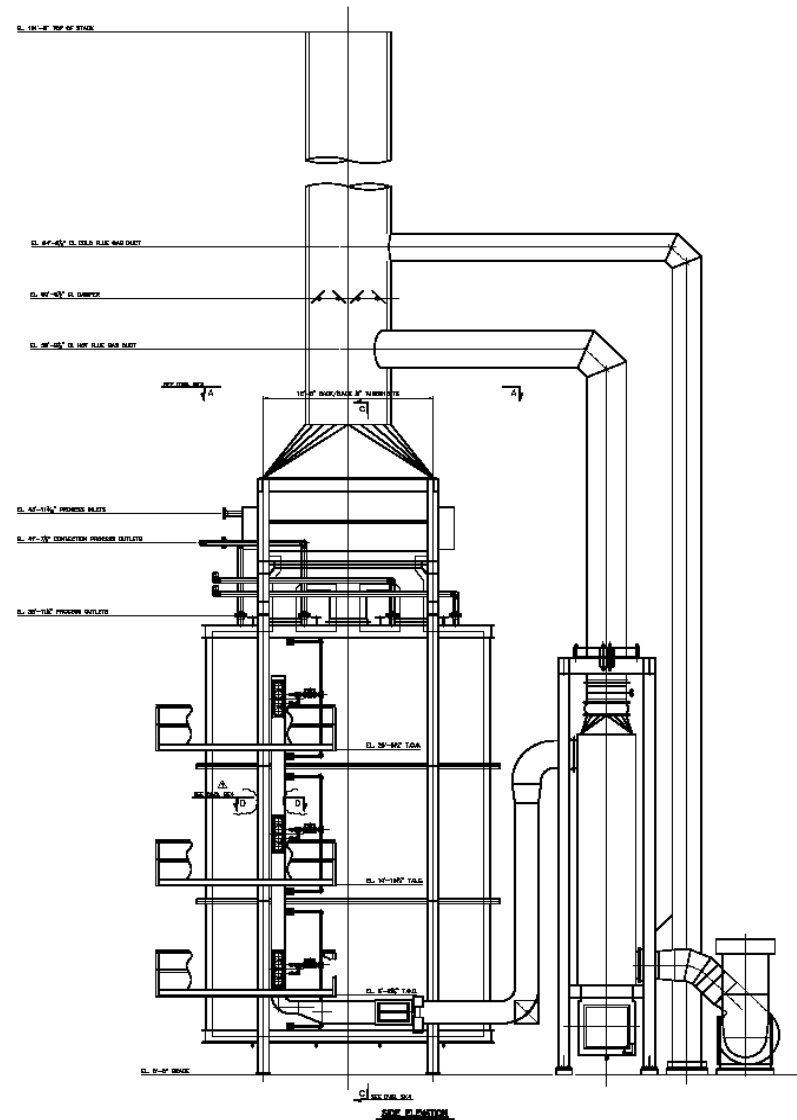

Great Southern Flameless, LLC

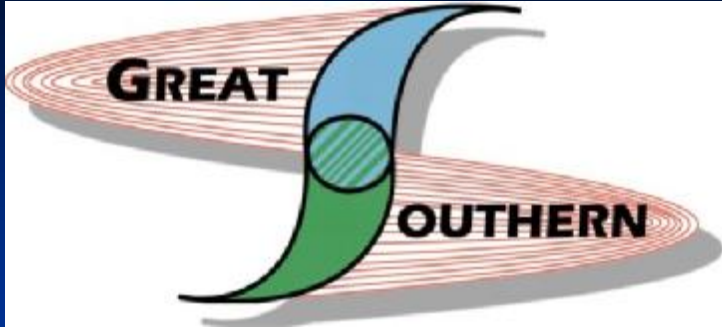

# Typical GSF Cabin Heater Coil Layout

Elevation End View

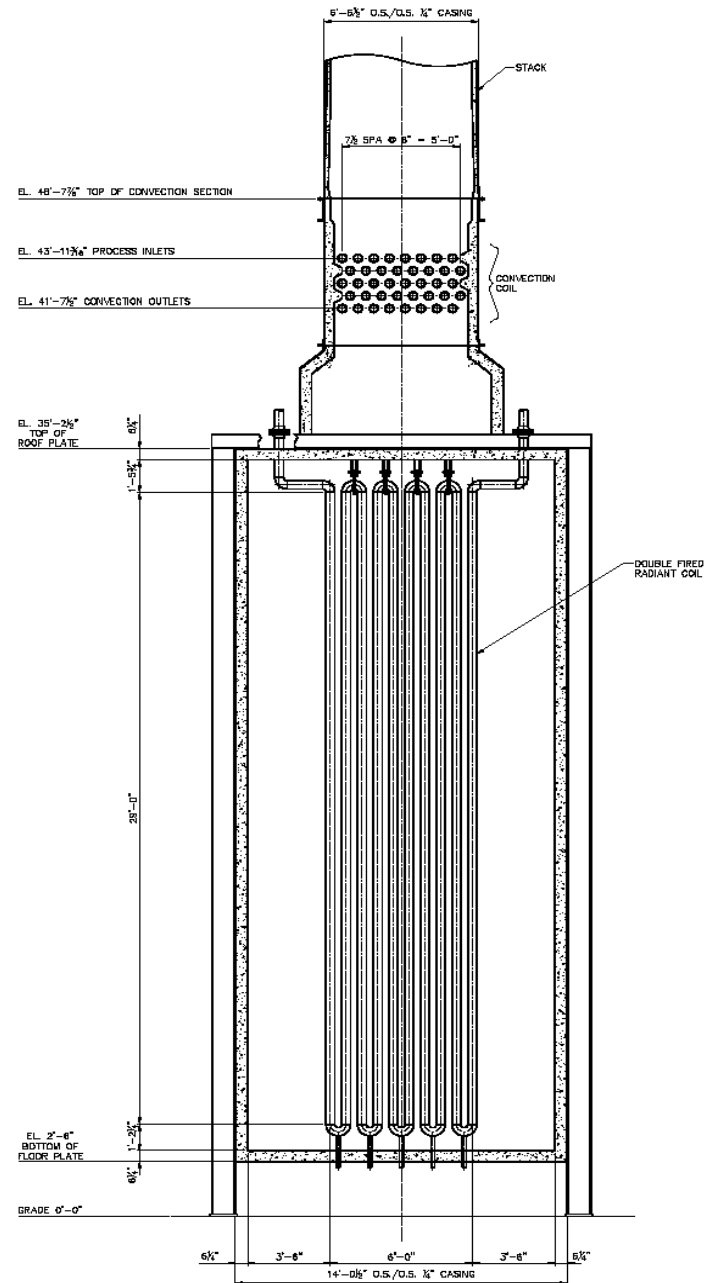



Great Southern Flameless, LLC

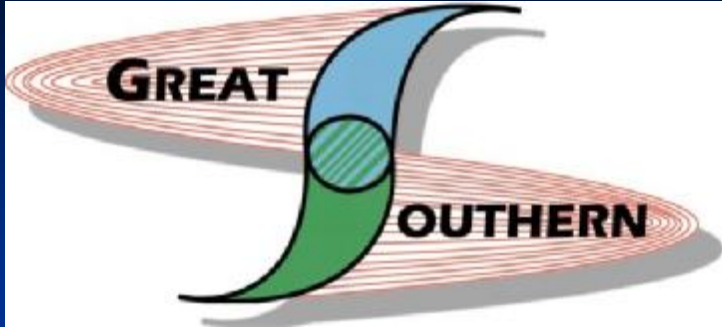

# Typical GSF Cabin Heater Coil Layout

Elevation Side View

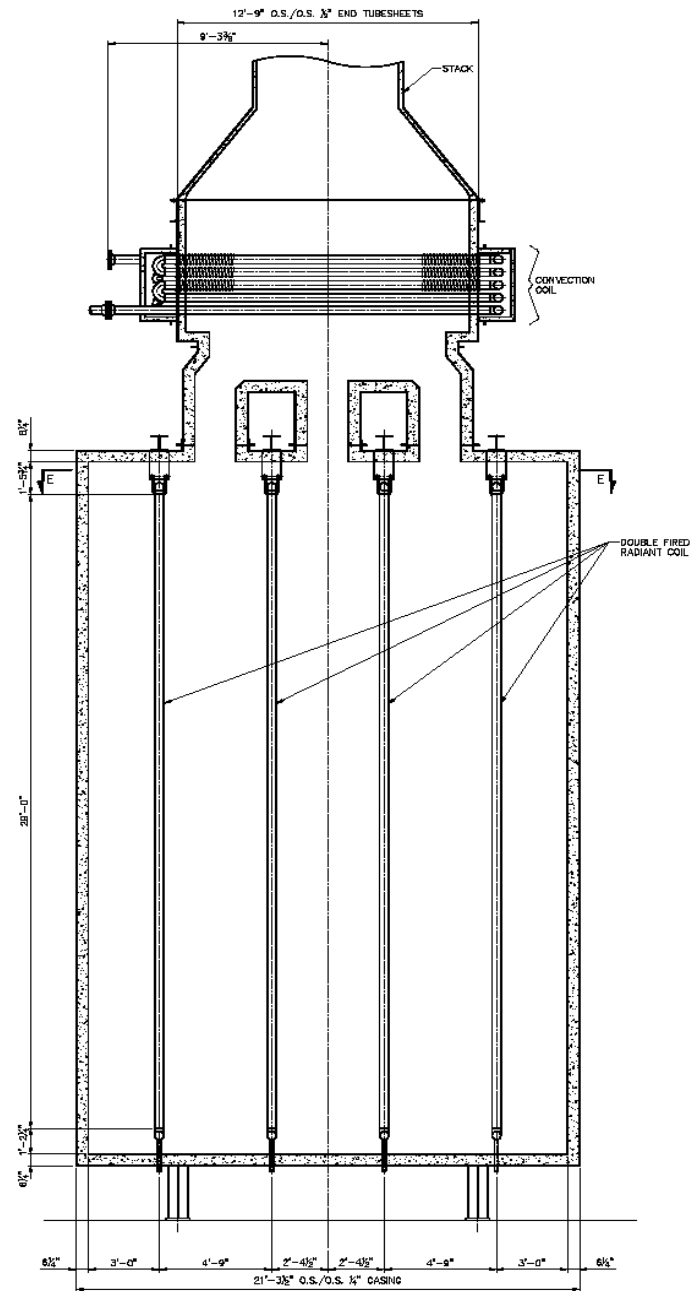

# Plan View of Coil Layout

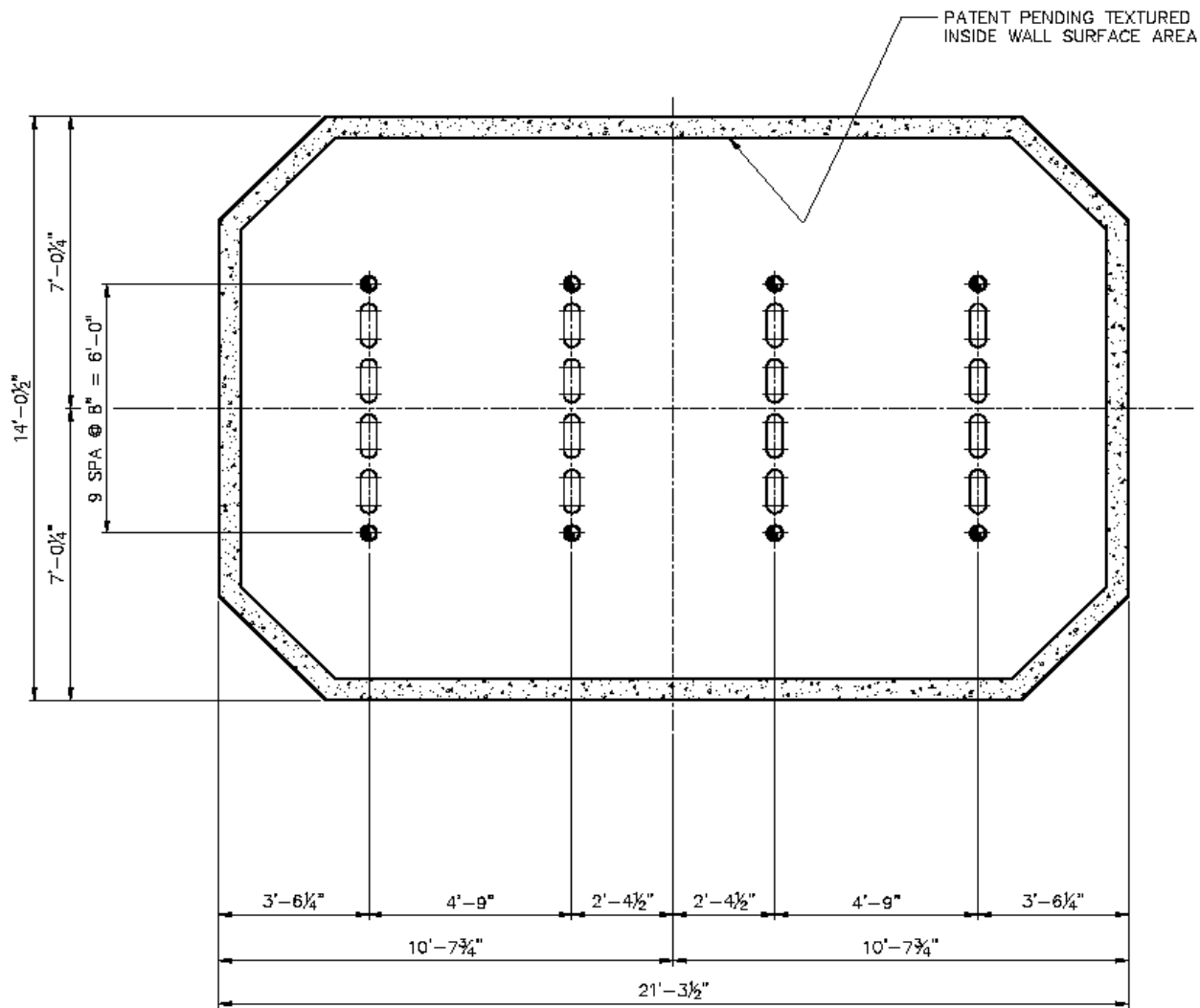

# Air and Fuel Nozzle System

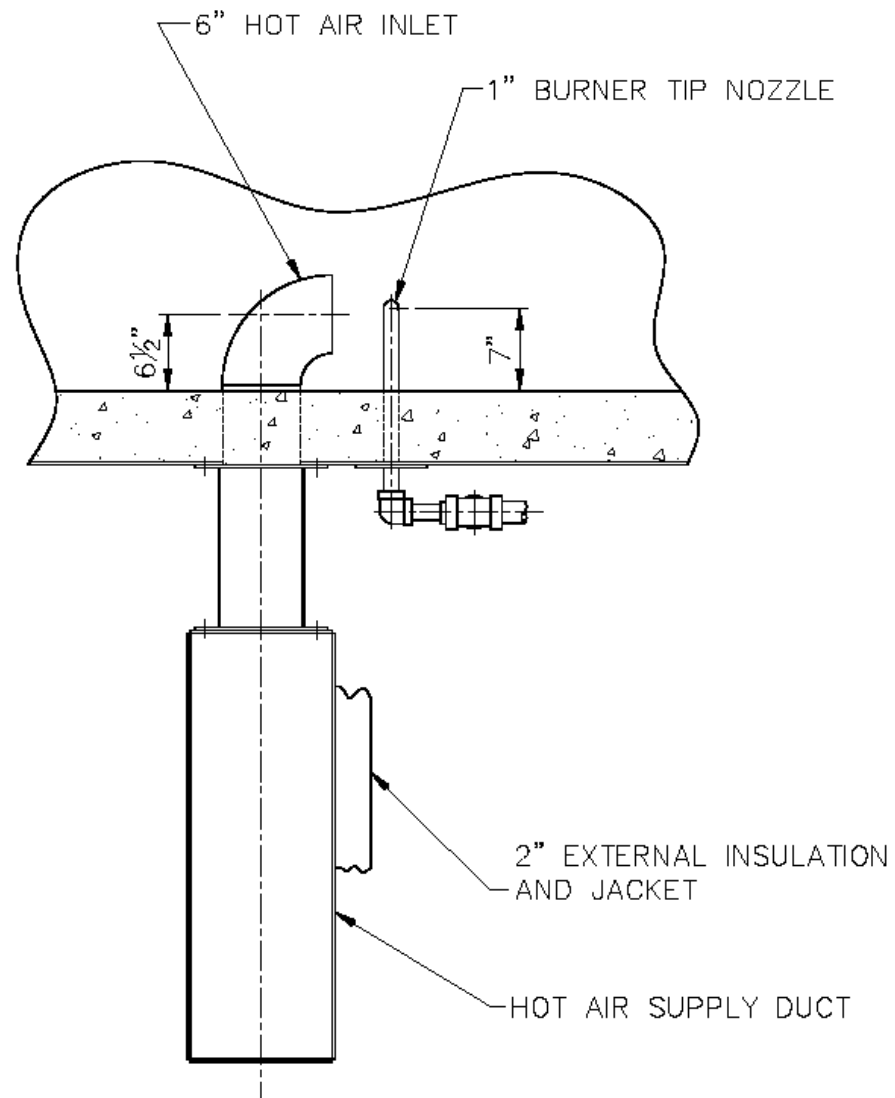

# Conventional to Flameless Control

## GSF's Fuel Delivery System

(patent pending)

Conventional Firing

50% Conv/50% Flameless

Flameless Firing

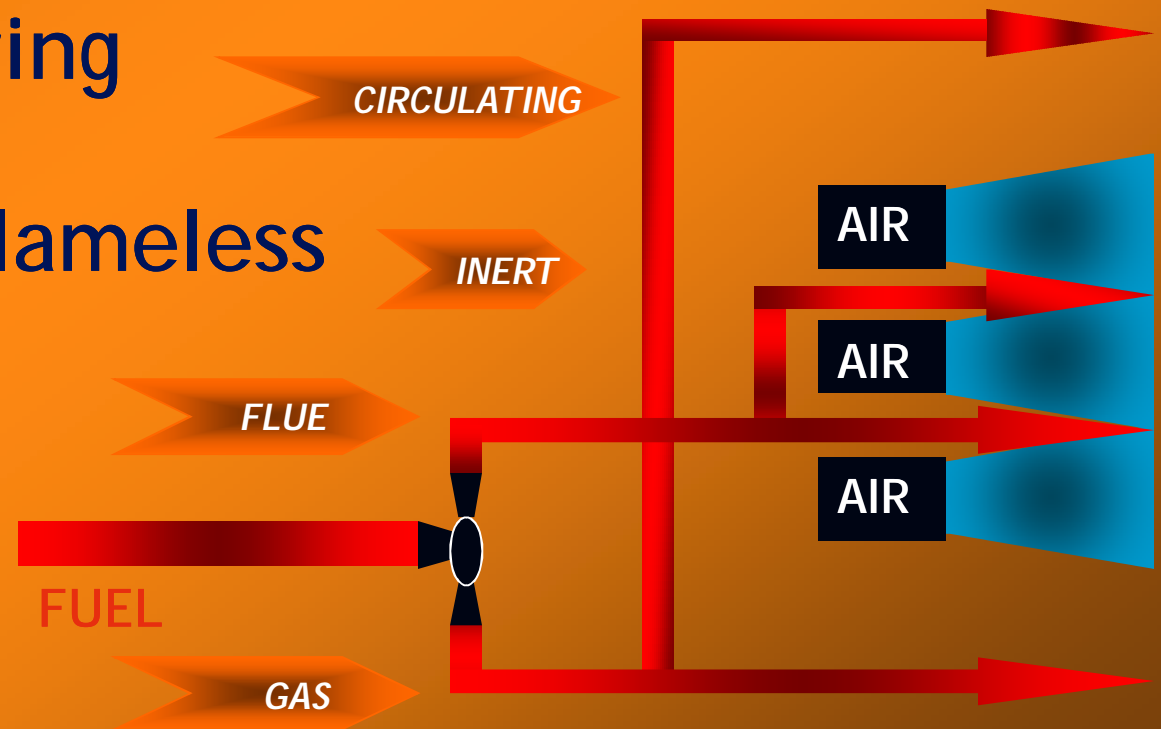

# Sustaining Flameless Combustion

(patent pending)



HTAC Together With GSF's Proprietary  
Refractory Wall Texture

\*\*\*

Localized Temperatures Are Maintained  
Above Auto-Ignition Temperature  
of the Fuel, Air and Flue Gas  
Mixture

# Flameless Application Issues

🔥 Create flameless combustion in a relatively low temperature/low flux application

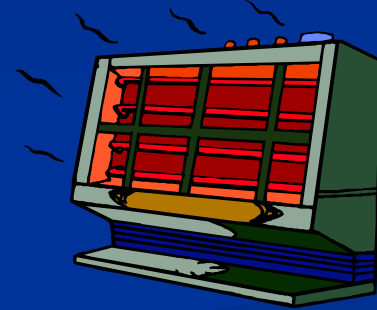

🔥 Safely & reliably go from conventional to flameless

- AND -

🔥 Safely & reliably go from flameless to conventional

# GSF's Conventional Heater with Flameless Capability

## Key Benefits

- 🔥 Wide Range of Operation
- 🔥 SCR Level NO<sub>x</sub> Emissions (3-8 ppm)
- 🔥 HTAC - Recuperative Air Pre-Heater (industry standard)
- 🔥 Up to 11% Improved Efficiency
- 🔥 Up to 11% CO<sub>2</sub> Reduction
- 🔥 Even Radiant Heat Flux
- 🔥 Longer Run Lengths with Increased Throughput

# HEATER TECHNOLOGY COMPARISON

Radiant Coil Configuration: Double Fired  
 Absorbed Duty: 100 MMBtu/hr      Excess Air: 15%  
 Fuel Composition: 30% H<sub>2</sub>, 50% CH<sub>4</sub>, 20% C<sub>3</sub>H<sub>8</sub>

	FLAMELESS MAXIMUM EFFICIENCY	FLAMELESS BASELINE	CONVENTIONAL NATURAL DRAFT
Air Preheat	Yes	Yes	No
Combustion Air Temp, °F	890	890	60
Stack Temp, °F	240	300	650
Bridgewall Temp, °F	1537	1537	1537
Heat Release (LHV), MMBtu/hr	107.5	109.9	121.2
Heater Efficiency (LHV), %	93	91	82.5
Heater Efficiency (HHV), %	83	81	72.5
Energy Savings (LHV), MMBtu/hr	13.7	11.3	NA
CO, ppmvd	<50	<50	<50
NO <sub>x</sub> , ppmvd corrected to 3% O <sub>2</sub>	3-8	3-8	20
NO <sub>x</sub> , lb/MMBtu (HHV)	.006	.006	.024
NO <sub>x</sub> , lb/hr	0.723	0.741	3.31
NO <sub>x</sub> reduction, lb/hr	2.587	2.569	NA
NO <sub>x</sub> reduction, %	78.2	77.6	NA
CO <sub>2</sub> , lb/hr	13867.5	14177.1	15634.8
CO <sub>2</sub> reduction, lb/hr	1767.3	1457.7	NA
CO <sub>2</sub> reduction, %	11.3	9.3	NA



# More Key Benefits

- 🔥 Flexibility - Compatible With Natural Gas, Refinery Fuel Gas, 100% H<sub>2</sub> and 100% Oxygen
- 🔥 Large Fuel Injection Ports for Lower Maintenance Cost
- 🔥 Eliminates Need for Fuel Filter/Coalescer
- 🔥 Reduces Cost of NO<sub>x</sub> and Future CO<sub>2</sub> Credits

# HEATER TECHNOLOGY COMPARISON

Radiant Coil Configuration: Double Fired

Absorbed Duty: 100 MMBtu/hr      Excess Air: 15%

Conventional Fuel Composition: 30% H<sub>2</sub>, 50% CH<sub>4</sub>, 20% C<sub>3</sub>H<sub>8</sub>

Flameless Fuel Composition: 60% H<sub>2</sub>, 20% CH<sub>4</sub>, 20% C<sub>3</sub>H<sub>8</sub>

	FLAMELESS MAXIMUM EFFICIENCY	FLAMELESS BASELINE	CONVENTIONAL NATURAL DRAFT
Air Preheat	Yes	Yes	No
Combustion Air Temp, °F	890	890	60
Stack Temp, °F	240	300	650
Bridgewall Temp, °F	1537	1537	1537
Heat Release (LHV), MMBtu/hr	107.5	109.9	121.2
Heater Efficiency (LHV), %	93	91	82.5
Heater Efficiency (HHV), %	83	81	72.5
Energy Savings (LHV), MMBtu/hr	13.7	11.3	NA
CO, ppmvd	<50	<50	<50
NO <sub>x</sub> , ppmvd corrected to 3% O <sub>2</sub>	3-8	3-8	20
NO <sub>x</sub> , lb/MMBtu (HHV)	.006	.006	.024
NO <sub>x</sub> , lb/hr	0.723	0.741	3.31
NO <sub>x</sub> reduction, lb/hr	2.587	2.569	NA
NO <sub>x</sub> reduction, %	78.2	77.6	NA
CO <sub>2</sub> , lb/hr	12497.9	12776.9	15634.8
CO <sub>2</sub> reduction, lb/hr	3136.9	2857.9	NA
CO <sub>2</sub> reduction, %	20.1	18.3	NA

# And Still More...

- 🔥 The Capital Cost of a GSF Heater is Comparable to a Typical Conventional, Double Fired Heater with Balanced Draft, Air Pre-Heat System
- 🔥 **GSF Technology is for New Heaters or Retrofits**



# Economic Comparison

Fuel Cost Basis: \$8.00/MMBtu (LHV)

	FLAMELESS MAXIMUM EFFICIENCY	FLAMELESS BASELINE	CONVENTIONAL NATURAL DRAFT
Base Heater Cost, \$	3,000,000- 4,000,000	3,000,000- 4,000,000	3,000,000
Air Preheat Cost, \$	837,900	700,000	0.00
Yrs to Pay for Preheat System	0.87	0.88	NA
Flame/Gas Impingement on Tubes	No	No	Yes
Increased Run Length	Yes	Yes	No
Increased Tube Life	Yes	Yes	No
Even Heat Transfer to Radiant Coil	Yes	Yes	No
Burner-Burner Flame Interaction	No	No	Yes
Multi-Burner Effect NOx Increase	No	No	Yes

# Speed of Implementation Issues

🔥 Market Acceptance of Conventional vs. Flameless Heaters

Now You Can Have **BOTH**

🔥 Zero Risk: Conventional Heater that Can Be Operated in Flameless Mode for Extreme  $\text{NO}_x$  and  $\text{CO}_2$  Reduction

# Conclusion

It's Time To  
"Kick the Tires"

on

Flameless Combustion  
Technology

# Path Forward

## Combined Technologies

- ü Pre-Combustion Fuel Conditioning
- ü High Efficiency Combustion Processes
  - ü Oxy-Fuel
  - ü HTAC
  - ü Flameless
- ü Post-Combustion CO<sub>2</sub> Capture and Storage

## Requires Joint Efforts

- ü Industry
- ü Academia
- ü Government Entities

Please contact us to join efforts or for additional information:

[Info@GreatSouthernGroup.com](mailto:Info@GreatSouthernGroup.com)

# Questions and Answers

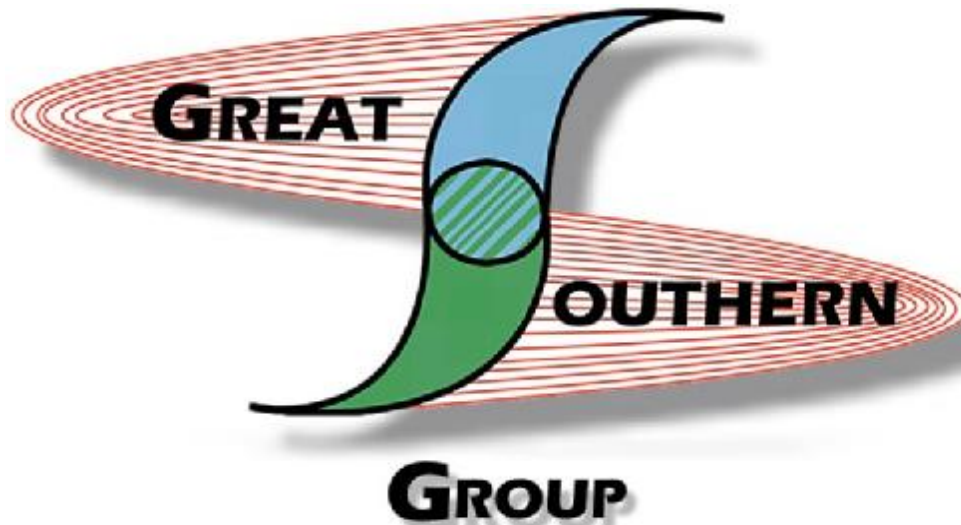

---

Great Southern  
Technologies, LLC

Great Southern  
Flameless, LLC

Great Southern  
Independent, LLC

[www.GreatSouthernGroup.com](http://www.GreatSouthernGroup.com)

*Significantly different companies.*